

Signature RFID - Contact Less

RFID: Radio Frequency Identification

Radio Frequency Identification (RFID), future technology in electronic locking systems for hotels.

Signature RFID by VingCard offers the latest Radio Frequency Identification (RFID) technology with the most flexible platform for future applications:

RFID Specifications

- 13,56MHz technology
- Compatible with the following standards:
 - ISO 14.443 A (MIFARE)
 - ISO 14.443 B
 - ISO 15.693
- Compatible with Near Field Communication (NFC) standards.



Get **More** with Contact **Less** - Benefits:

- More **Guest Satisfaction**: Unmatched ease of use for guests of all ages. No need to insert the keycard, more intuitive.
- More **Security**: anti-cloning technology for all guest and staff cards. Unlike Mag-stripe whose keycards can be cloned, RFID technology allows powerful anti-cloning solution.
- More **Adaptability**: RFID keycards and carriers adapt to any hotel style: You can choose from low cost guest cards, long lasting staff cards, wristbands and keyfobs to perfectly match different hotel types: Business, Resort, Spa, All-inclusiv.
- More **Information and Control**: Signature RFID electronic lock can write back information on staff RFID keycards for better information and management: Staff card audit trail, low battery status, cylinder tamper alarm.
- More **Integration**: You can integrate and interface Signature RFID keycards with other applications at your hotel (loyalty programs, vendor payment, etc).
- More **Exclusivity**: Provide a new experience for your customers and enhance the image of your hotel
- More **Robustness**: Signature RFID electronic lock components are sealed and provide better performance for outdoor use.
- More **Selection**: Provides access today to next generation technologies, including NFC-cell phone.
- And **Less guess-work** out of selecting the right technology. Signature RFID by VingCard offers 4 technology standards in 1 electronic lock.

Features:

- Stand alone electronic lock with RFID technology.
- Fire listed for usage on fire doors. (UL, EN, BS).
- High security mortise lockcase available in ANSI, JPN, AUS and EURO versions.
- CE, FCC approved.
- Solid brass handle with self lubricating long life bearings.
- 3 point steel latch construction with an antifriction mechanism.
- Case hardened full 1-inch (ANSI) throw deadbolt.
- Panic release function – the deadbolt and latch are automatically retracted by inside handle for easy egress in emergency situations.
- ADA compliant (guests with physical disabilities).
- Future proof re-programmable FLASH RAM lock memory.
- Powered by 3AA batteries that provide up to 3 years normal life time.
- 600 event audit trail.
- Compatible with VISION system Software platforms.
- Optional high security mechanical override.
- Upgrade kit from Signature by VingCard mag stripe or combo technology reader to RFID technology:
 - Only need to replace the reader unit and escutcheon. A few minutes operation. No need to replace the lockcase, or handles.*

A wide range of RFID (contact less) carriers

VingCard offers a wide range of RFID carriers that are especially designed for different applications (for your guests, for your staff or for your VIP guests) and gives you the opportunity to enhance your guests' experience at your hotel.

Typical hotel application:

Guests: Low cost guest keycards.
Staff: Long lasting staff keycards.
VIP guests: Keyfobs and cell phones.

Typical resort & spa application:

Guests: Wrist band for guest convenience and all-inclusive.
Staff: Long lasting staff keycards.
VIP guests: Wristbands or keyfobs.



Low cost guest keycards:
Cards may be customized at your request.



Long lasting staff keycards:
Cards may be customized at your request.



Keyfobs:
Tags may be e.g. a keychain, and can be customized at your request.



Wristbands:
The ideal RFID carrier for 'all-inclusive' resorts and spas.



Cell phone:
Compatible with NFC technology cell phones.

All RFID carriers may be mixed within one property, providing you with flexible solutions.

Compatible with Near Field Communication (NFC) standards:

NFC technology enables RFID communication between our electronic locks with NFC-ready last generation cell phones.

- Guests can receive an encrypted room key and room number to their cell phone prior to their arrival, thus no need to check in at front desk.
- Guests can use their own NFC-ready cell phones to open the Signature RFID electronic lock.



www.nfc-forum.org



Quick path from standard Signature to RFID reader technology

Upgrade kit from Signature by VingCard mag stripe or combo technology reader to RFID technology by replacing the reader unit and escutcheon only.

- 3-5 minutes operation.
- No disturbance or inconvenience for your guests.
- No need to replace the lockcase, or handles.
- No drilling required.
- No downtime in-room availability.



Color options:

The RFID reader is available in Black and also 4 optional colors: Red, Orange, Green and Blue.

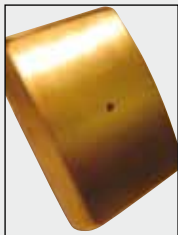
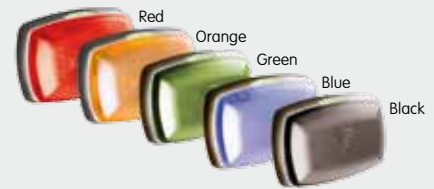

Battery cover options:

Optional metal battery cover matching the handle and metal ring is available.

Dimensions:

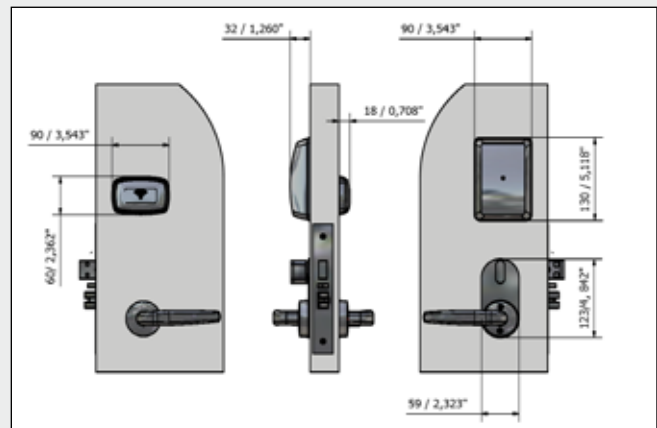

Emergency cylinder option

VingCard locks may also be supplied with an optional mechanical override cylinder, widely recognized as the finest in the industry.

- Use of mechanical override is registered in the lock memory for audit trail.
- Mechanical cylinder can be either visible or not visible with a cylinder concealer.
- Superior pick resistance through its 7 pin high security profiles and narrow channel paracentric keyway anti pick drivers.
- Unique cylinder fixing for added security.
- 5 times recodable cylinder (incl. 2 construction levels).
- Cylinder is available in all lock finishes. (Satin finishes may vary from lock finish).



SPECIFICATIONS

ANSI DB lockcase:

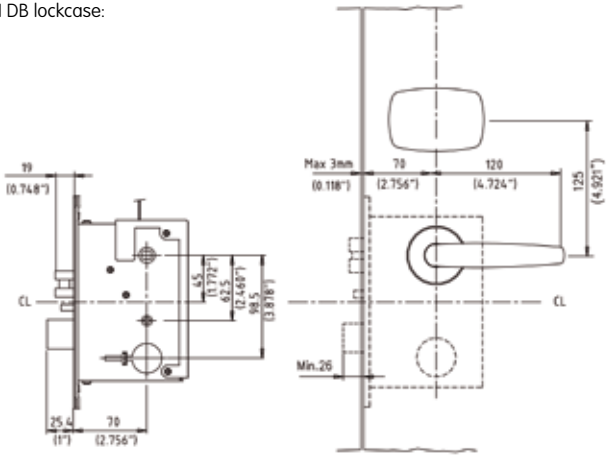

AUS lockcase:

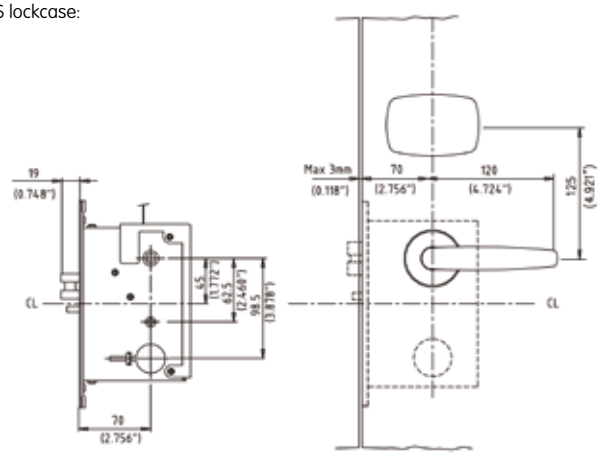

ANSI DA lockcase:

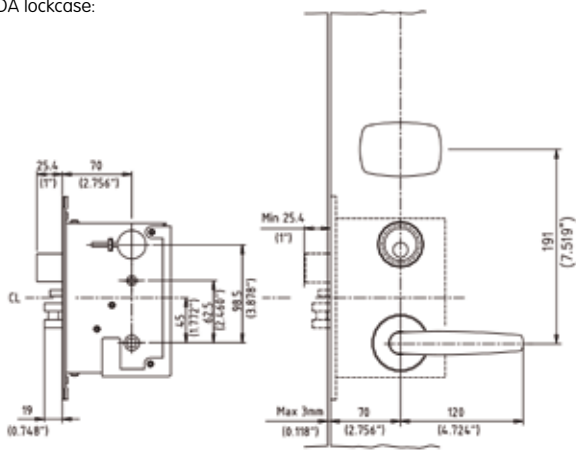

JPN lockcase:

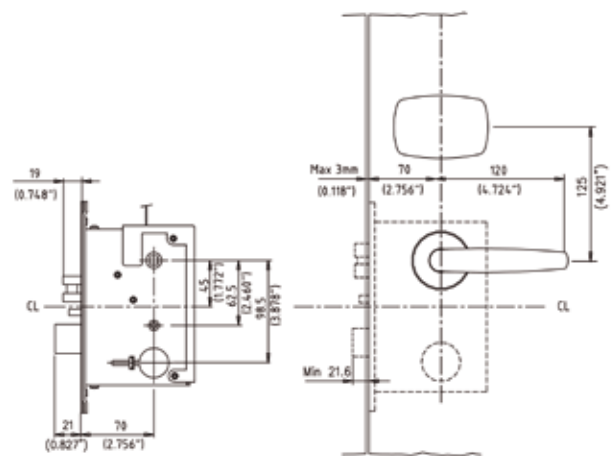

EURO lockcase:

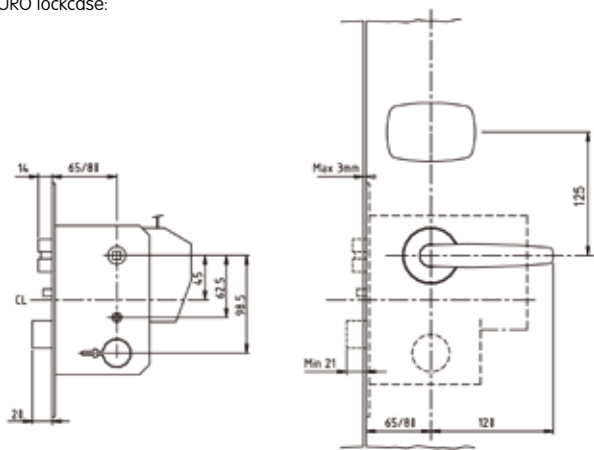

ANSI:

- 25 mm front
- 28 mm front
- 32 mm front

Backset: 70 mm

EURO:

- 20 mm front
- 22 mm front
- 24 mm front

Backset: 65 mm/80 mm

Get More with Contact Less

Contact us:

Signature
by VingCard®

VingCard
Elsafe

ASSA ABLOY

VingCard Elsafe AS

P.O. Box 511 • 1522 Moss • Norway

Tel: +47 69 24 50 00 • Fax: +47 69 24 50 50

E-mail: info@vcegroup.com • www.vcegroup.com